

TALAS

Paardenkerkhofstraat 56 B-2800 Mechelen
 Tel. +32(0)15.61.60.07 Fax. +32(0)15.61.75.27
 Email. info@talas.be www.talas.be

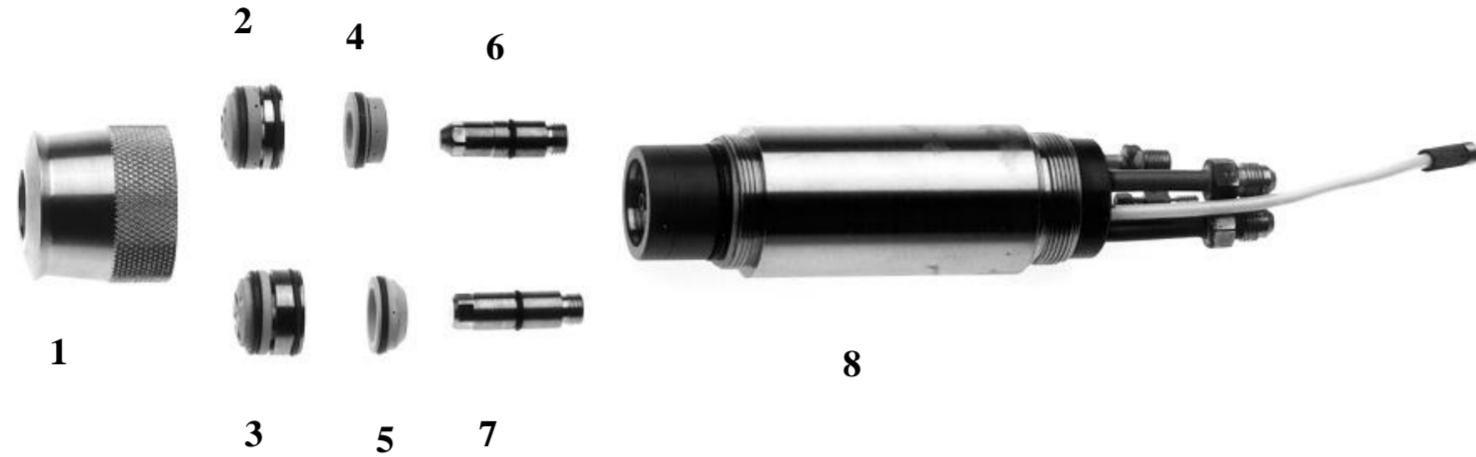

PAC 600-620™



Item No.	Pkg Qty	Centricut Part #	Ref Number	Description	
1	1	H22-580	020580	Retaining Cap, N2, Vectra	
	1	H04-286	020286	Retaining Cap, N2, Vespel	
	1	H04-579	020579	Retaining Cap, O2, N2, WM, Vectra	
	1	H04-246	020246	Retaining Cap Flared, O2, N2, WM, Vespel	
3	1	C22-281	020281	Nozzle, N2, .120, 200 Amp	
	1	C22-282	020282	Nozzle, N2, .166, 400 Amp	€ 19,25 10pcs
	1	C22-283	020283	Nozzle, N2, .187, 600 Amp	€ 19,25 50pcs
	1	C22-284	020284	Nozzle, N2, .220, 760 Amp	
	1	H22-321	020321	Nozzle, .250, ArH2	
2	1	C04-086	020086	Nozzle, O2, .099, 260 Amp	€ 20,72 80pcs
	1	C04-392	020392	Nozzle, O2, .099, 260 Amp, CCW	
4	1	C04-380	020380	Swirl Ring, O2, .099, 4 Hole	
	1	C04-391	020391	Swirl Ring, O2, 260 Amp, CCW, 4 Hole	
5	1	C05-039	020039	Swirl Ring, N2, .120/.166/.187	
	1	C05-042	020042	Swirl Ring, N2, .120/.166/.187, CCW	
	1	C05-040	020040	Swirl Ring, N2, .220, 750 Amp	
	1	C05-079	020079	Swirl Ring, N2, .220, CCW	
	1	C05-048	020048	Swirl Ring, .250, 1000 Amp	
6	1	C04-081	020081	Electrode, O2, 260 Amp	€ 14,08 40pcs
7	1	C22-285	020285	Electrode, N2, ArH2	€ 16,86 40pcs
	5	C05-028	025028	O-Ring Kit	
	1	HYP-7055	027055	O-Ring Lube	
8	1	C22-928	N/A	PAC600 Modular Torch	
	1	C22-328	N/A	Torch Body, PAC600	
9	1	C04-047	N/A	Cooling Tube, Modular Torch	€ 8,79 2pcs
	1	C04-941	020041	Insulating Sleeve, threaded both ends	
	1	C04-048	N/A	Cooling Tube Wrench	
	1	C27-111	N/A	Electrode Wrench	

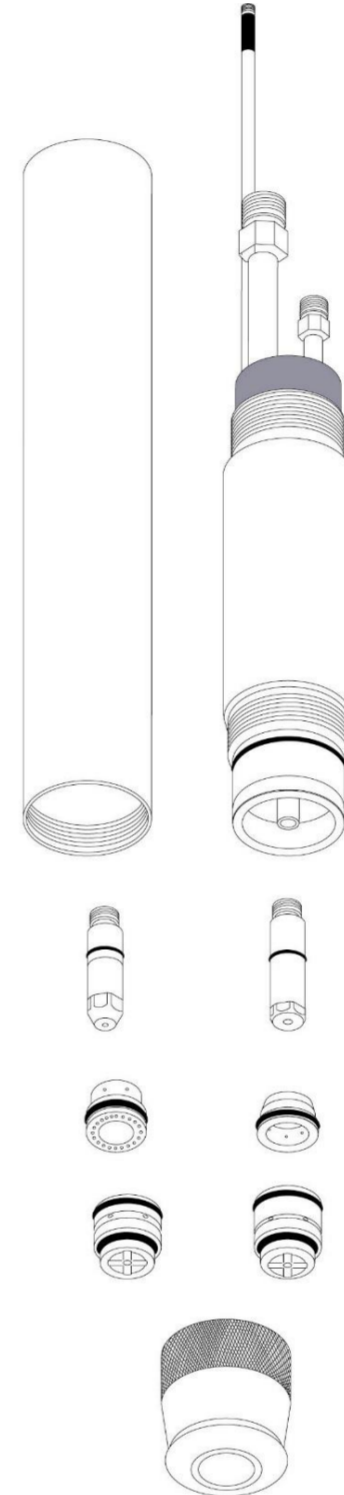

Reference to the above-named machines, torches, and reference numbers are for convenience only. All products with a "C" in the part number are manufactured by or for Centricut, LLC. The use of other prefixes indicate parts manufactured by the above-named OEM, which are simply being resold by Centricut, LLC., and will be supplied in OEM packaging.