

Superior Solutions for Sheet Metal Fabricators

# Premia™

Sharpening  
System



PN 2013

**WORLDWIDE HEADQUARTERS:**

1295 Lund Boulevard, Anoka, Minnesota 55303 USA

Tel 763.421.0230 Fax 763.421.0285

Toll Free: Tel 800.328.4492 Fax 800.541.0285

[mate.com](http://mate.com)



TRUSTED | QUALITY | SERVICE | SOLUTIONS

# MATE PREMIA™ SHARPENING SYSTEM

Proper tooling maintenance is critical to produce high quality parts, increase machine uptime and extend tool life. Mate's Premia Sharpening System ensures the proper result for every sharpening operation. With Premia's easy-to-use touch screen interface, powerful high-output motor and ability to accept any tooling style, keeping your tooling in optimal condition has never been easier!

## Innovation

- Touch-screen interface simplifies all set-up and maintenance operations. Supports multiple languages and units of measure. Easily updateable software via USB port and SD card.
- Data Tracking - Number of punch press tools sharpened, wheel and coolant life, motor life and more. Predictive wheel replacement warning.
- Solid-surface 7.8" (200mm) CBN grinding wheel optimizes performance. Eliminating the perpendicular slots directly translates to a longer-lasting wheel.
- Innovative design allows automatic coolant flow directly through the grinding wheel.
- Superior dual-stage filtering process features Mate's proprietary MSR™ (Magnetic Swarf Retention) technology, for longer maintenance intervals and extended coolant pump life.
- On screen alerts/warnings for "Add Coolant" (low coolant) and "Change Filter" (high coolant).

## Effortless Operation

- Ideal for unsupervised operation... just press "Start Grinding" and Premia will sharpen the tool without assistance.
- Light signals when current sharpening cycle is finished - no need to wait by machine.
- Store multiple programs to ensure consistency no matter who operates the machine.
- Powerful 3.3kW motor can handle the largest tools.

## Flexibility

- Three standard programs (one each for small, medium and large tools) and two user-customizable programs. Full manual mode for unique situations also included.
- Universal fixture accommodates virtually all tooling styles.
- Fine grind depth and removal rate settings provide maximum flexibility, reliability and consistency.
- Angular table adjustment from 0° to 12° allows shears (including whisper and rooftop) to be ground on punches for optimal punching efficiency.

## Convenience

- Status report screen with complete sharpening and wheel maintenance data log.
- Two drawers for convenient storage of tooling awaiting maintenance or other items such as measuring instruments.
- 10.5 gallon (40 liter) coolant tank on wheels. Easy-to-remove for changing coolant and tank cleaning.
- Hand sprayer

## Safety

- Fully enclosed work area ensures safety.
- Door interlock prevents Premia operation with door open.
- Abrasive mist contained during sharpening process. Keeps work area clean while eliminating slip hazards. Keeps abrasive sharpening mist out of the air and off of other expensive machinery.
- CE and QPS certified.



# MATE PREMIA™ SHARPENING SYSTEM

## TOUCH SCREEN CONTROL PANEL

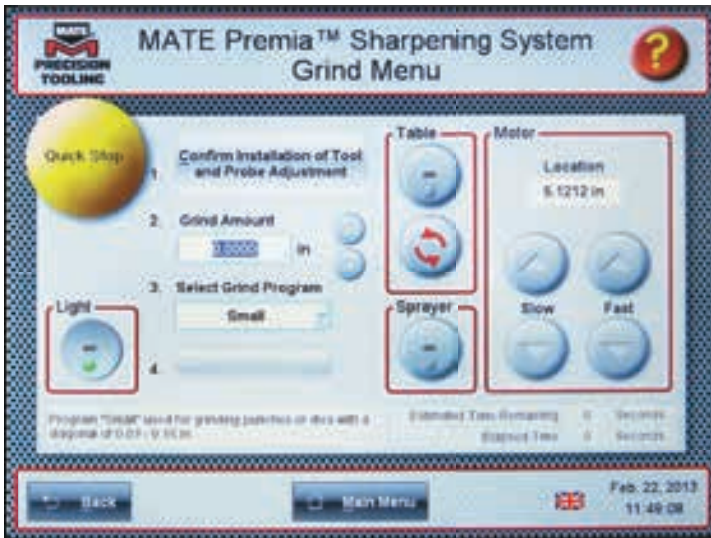

### MAKES OPERATION EASY!

**Step 1 – Install**

- Install tool into universal grinding fixture.

**Step 2 – Enter**

- Enter the amount you want to remove.

**Step 3 – Select**

- Select from one of three pre-set programs, or create two custom programs.

**Step 4 – Start**

- Press “Start Grinding” for automatic operation!



A wide variety of punch press tooling systems are fully compatible with the Premia Sharpening System.



Premia even sharpens complicated whisper shears on Trumpf-style punches.



Small diameter punches can be ground without breakage.



Large station dies can be sharpened quickly with high quality surface finish.



Rooftop shear may be sharpened easily by using the graduated tilt mechanism.



# MATE PREMIA™ SHARPENING SYSTEM

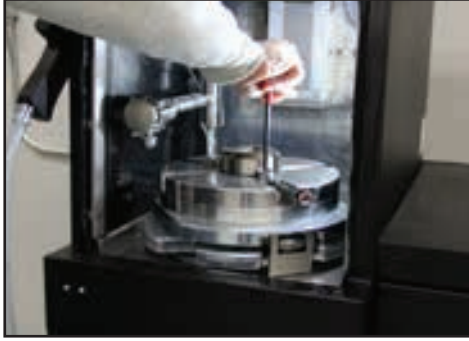

## Tool Installation:

Mount the tool into Premia's Universal Fixture. The fixture locates the tool precisely and provides rigid support for the tool during operation.



**The Premia Sharpening System includes** a graduated angle plate that allows a shear (rooftop, whisper, or one-way) to be ground on to punches easily. Simply tilt the plate and use the graduated cam to select the appropriate angle up to 12°.



## The Premia Sharpening System accommodates a full range of punch press tool styles:

- Thick Turret
- Trumpf style
- Murata Wiedemann
- Multi Tool
- Thin Turret
- Salvagnini
- XMT
- More!

*(See chart on page 6)*



## Programming:

Select from one of 3 pre-set and 2 custom programs using the simple control panel. The programs are easy to enter and include:

- Rough-cut feed depth and feed speed (Course grind; most of the material is rapidly removed)
- Fine-cut feed depth and feed speed (Polishing grind; remaining material is slowly removed)
- Spark-out time at the end of the cycle (Final step; machining forces are removed)

Precise control of the feeds and speeds ensure optimum grinding conditions are achieved to suit a wide range of applications, from the narrowest punch to the largest die.





# MATE PREMIA™ SHARPENING SYSTEM

## Automatic Operation:

The fully enclosed cabinet design and automatic coolant system makes Premia ideal for unsupervised operation. Once the tool is mounted, and the program is selected, a simple “Start Grinding” button starts the process.

**The indicator light** on the top of the Premia flashes during operation and stops upon completion of a program.



## Dual Stage Coolant Filtration Extends Coolant Life

- Stage 1 uses Mate’s proprietary MSR™ (Magnetic Swarf Retention) technology
  - Magnetic system captures up to 80% of sharpening swarf before it reaches stage 2
- Stage 2
  - Replaceable filter helps trap remaining swarf
- MSR tray is easily removed for cleaning and maintenance

**The Coolant Sprayer** allows the part to be rinsed prior to its removal from the machine, and easy cleaning of the fixture and work area.

*See your operating manual for complete instructions.*



## PREMIA SHARPENING SYSTEM – UNIVERSAL FIXTURE

The Premia Universal Fixture allows virtually all styles of punch press tooling to be held securely during operation in Premia. Benefits include:

- **Universal** – designed to work with all popular punch press tooling styles.
- **Robust** – hardened components withstand the abrasive operating environment.
- **Simple** – innovative design with sliding t-slot clamps for simple operation.

The Universal Grinding Fixture accepts a complete range of punch press tooling.

*(See chart on page 6)*



# TOOLING SYSTEM COMPATIBILITY

Premia Sharpening System is designed for use with all popular punch press tooling systems.

Thick Turret	Thin Turret	Trumpf Style	Murata	Salvagnini, MultiTool, Other
<b>Ultra TEC®</b> A - 1/2" B - 1-1/4" C - 2" D - 3-1/2" E - 4-1/2"	<b>Snap-Apart</b> 1/2"	<b>NEXT™</b> Size 40 Size 76	<b>Marathon®/114</b> A, B, C, D, E, F, G, H, J, K, L stations	<b>Salvagnini</b> Type II 33mm Type III 60mm Type III 70x90mm Type III 90x90mm
<b>Ultra XT™</b> A - 1/2" B - 1-1/4" C - 2" D - 3-1/2" E - 4-1/2"	<b>Drop-In</b> 5/8"	<b>QuickLock™</b> Size 1 Size 2	<b>Marathon®/112</b> A, B, C, D, E, F, G, H stations	<b>MT™</b> 8mm 16mm 24mm
<b>Original Style</b> A - 1/2" B - 1-1/4" C - 2" D - 3-1/2" E - 4-1/2"	<b>Full Body</b> 1-1/4" 2" 3-1/2"	<b>Standard Style</b> Size 0-A Size 0-B Size 1 Size 1-X Size 2 Size 3	<b>Varitool</b> 6 station 8 station 12 station	<b>XMT™</b> 12.7mm 24mm
<b>AMX</b> A - 1/2" B - 1-1/4" C - 2" D - 3-1/2" E - 4-1/2"	<b>MTG™</b> 3 station 8 station	<b>Multitool</b> 3 station 4 station 6 station 5 station 10 station	<b>Vulcan</b> X, A, B, C,D,E, F, G, H, J, K, L station	<b>Nova®</b> A, B, C, D, E, F, G stations
<b>MXC™</b> A - 1/2" B - 1-1/4" C - 2" D - 3-1/2" E - 4-1/2"				

## PREMIA SHARPENING SYSTEM – WARRANTY AND COVERAGE:

Each Premia Sharpening System ("machine") is warranted for 12 months from the original in-service date of the machine at the owner's location. The entire machine is warranted for repairs, including parts and labor, to correct any defect in materials or workmanship, except for normal maintenance items. Needed repairs will be performed using new, remanufactured or refurbished parts. See product warranty for complete details. Owner must register their machine at [mate.com](http://mate.com) to start warranty.

The following items/conditions are not covered by the Premia Sharpening System Limited Warranty:

- Normal maintenance items: grinding wheel, lubricants, coolant, filters, light bulbs are excluded from the warranty
- Damage due to accident, misuse, alteration, insufficient or improper maintenance, contaminated or poor quality coolant or lubricant.
- Damage or corrosion due to chemical treatments, impact, use or environment.

An Important Note about Alterations and Warranties:

Installations or alterations to the machine as distributed by Mate are not covered by the Premia Sharpening System Limited Warranty. The machine owner assumes sole responsibility for any alterations (or any effect of the alterations) to any of the parts, components, systems, or assemblies made to the machine as distributed by Mate. Mate is not responsible for the safety or quality of design features, materials or workmanship of any alterations or installations completed by the machine owner, the machine owner's employee(s), or contractor/service hired by the machine owner.



# TECHNICAL SPECIFICATIONS

TECHNICAL SPECIFICATIONS	
Net weight	660 Lbs (300 Kg ±10 kg)
<b>GRINDING WHEEL:</b>	
Grinding wheel diameter	7.874" (200,00mm)
Grinding wheel type	CBN
Rotary Table Diameter	12.600" (320,04mm)
Maximum grind height	11.811" (300,00mm)
Shear angle capability	0° - 12°
Minimum Punch Diameter	0.031" (0,80mm)
Maximum Tool Diameter	7.50" (190,50mm)
Noise level	<67 dB(A)
<b>GRINDING MOTOR:</b> (*machine adjusts to power supply within specified range below)	
Power	3.3kW
Voltage	US — 440V-480V 3P 60 Hz. EU — 400V 3P 50 Hz.
Grinding motor RPM	US — 3440 at 60 Hz ±10% EU — 2820 at 50 Hz ±10%
<b>COOLANT SYSTEM:</b>	
Coolant pump power	120W
Coolant pump flow rate	13 gallons (50 liters) per minute minimum
Coolant reservoir capacity	10.5 gallons (40 liters)
Machine height	Approx. 76.5" (1943mm)
Machine width	Approx. 30" (762mm)
Machine depth	Approx. 26" (660mm)
Dual stage filtration system: featuring MSR™ technology - Separator tray, basket filter	

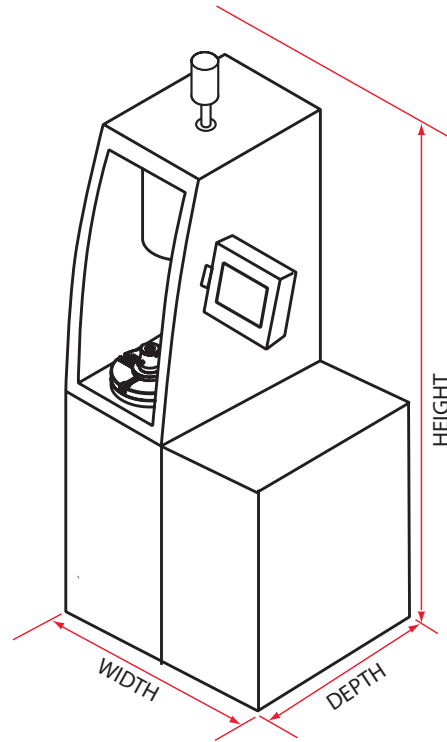

\*End user is required to provide appropriate electric connections.

Description	Part Number	Price
Premia Sharpening System with Universal Fixture Assembly	MATE02114	



[Dimensions in Inches (mm)]



Worldwide Headquarters: Anoka, Minnesota USA



European Headquarters: Oberursel, Germany



visit [mate.com](http://mate.com)

## MATE PRECISION TOOLING

### WORLDWIDE HEADQUARTERS:

1295 Lund Boulevard, Anoka, Minnesota 55303 USA  
Tel 763.421.0230 Fax 763.421.0285 [mate.com](http://mate.com)

© The Mate Logo is a registered trademark of Mate Precision Tooling Inc.  
Premia is a registered trademark of Mate Precision Tooling Inc.