

TALAS



CO₂ laser consumables – NTC-Beyeler®

TALAS

Paardenkerkhofstraat 56 B-2800 Mechelen
Tel. 015.61.60.07 Fax. 015.61.75.27 Email. info@talas.be

ACCESSORIES

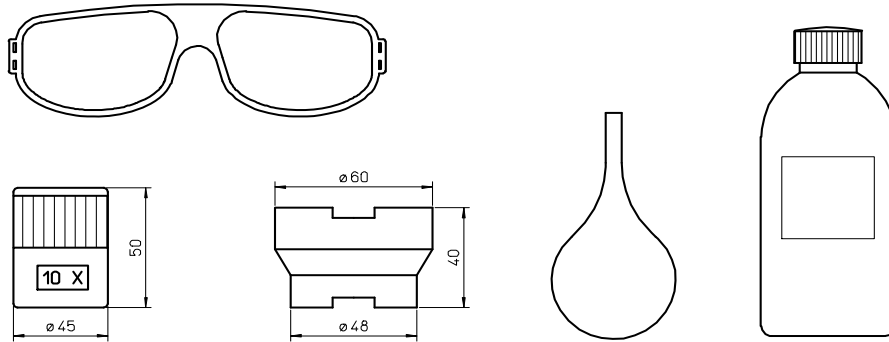

POS	Talas CODE	ORIGINAL CODE	DESCRIPTION
	AL1100		LASER CO ² GLASSES CE APPROVED
	AL1100017		LASER ECO CO ² GLASSES CE APPROVED 1.5-4.0kW
	AL1100015		LASER PROTECTOR CO ² GLASSES CE APPROVED 1.5-4.0kW
	AL1100018		LASER PROTECTOR CO ² GLASSES CE APPROVED 1.5-4.0kW
	GLADIATOR		LASER OVERGLASSES CO ² LIGHT VERSION 80g
	OVERSPEC		LASER OVERGLASSES CO ² VERSION 1500-4000W
	AL1001	123602	LENS CLEANING LIQUID - ml 200
	AL1001/L	123602	LENS CLEANING LIQUID - ml 1000
	AL1003-100	240568-100	LENS CLEANING POLISH - ml 100
	AL1003-200	240568-200	LENS CLEANING POLISH - ml 200
	AL1004		POLISH DETERGENT
	AL1010		DROPPER FOR LENS CLEANING LIQUID
	AL1120		LATEX GLOVES - 10 pieces
	ALI115		INDIUM WIRE Ø 1.0mm FOR 1.5" LENS
	ALI115/M		MAZAK® INDIUM 0.8mm FOR 1.5" MAZAK® LENS
	ALI120		INDIUM WIRE Ø 1.0mm FOR Ø 2.0mm LENS
	ALI120/M		MAZAK® INDIUM 0,8mm FOR 2,0" LENS
	SC50		LENS CLEANING PAPER - 75x135 - 50sheets
	SC100		KODAK LENS CLEANING PAPER - 70x120 - 50sheets
	SC105		LENS CLEANING PAPER - 100x105 - 50sheets
	SC20		COTTON SWAB -20 pieces
	AL1115		LENS CLEANING PRE-CUT COTTON - 100 pieces
	AL255	091860	SCALE LUPE
	AL271		BASE FOR LENS MAINTENANCE FOR 1,5" & 2,0" LENS
	AL282		INJECTOR
	350424-005		Lens Cleaning Holder 1.5" with Polarisors
	350423-005		Lens Cleaning Holder 2.0" with Polarisors
	910000		Lens Cleaning Kit
	020003-101		EZ Clean Wipes for Easy Lens Cleaning/ 24Pack

TALAS

Paardenkerkhofstraat 56 B-2800 Mechelen
 Tel. +32(0)15.61.60.07 Fax. +32(0)15.61.75.27
 Email. info@talas.be

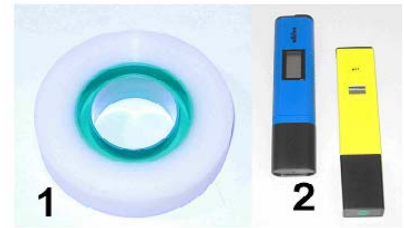

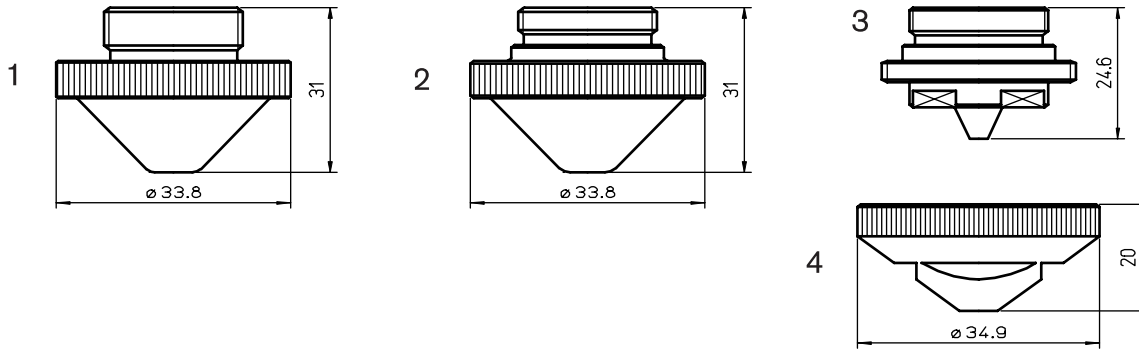

Consumables

Centricut part number	Reference number	Alternate reference	Description	Pkg qty
1 NT401-0001		L454	Nozzle – 1.0 mm	1
NT401-0002		L455	Nozzle – 1.2 mm	1
NT401-0003		L456	Nozzle – 1.5 mm	1
NT401-0004		L457	Nozzle – 2.0 mm	1
NT401-0005		L458	Nozzle – 2.5 mm	1
NT401-0006		L459	Nozzle – 3.0 mm	1
2 NT382-3738	4R019681	L1090	Nozzle – 1.0 mm	1
NT382-3737	4R023668	L1091	Nozzle – 1.2 mm	1
NT382-3904	4R020576	L1092	Nozzle – 1.5 mm	1
NT382-3739	4R019680	L1093	Nozzle – 2.0 mm	1
NT382-0025		L1096	Nozzle – 2.5 mm	1
NT382-3905	4R019770	L1094	Nozzle – 3.0 mm	1
NT382-0040		L1095	Nozzle – 4.0 mm	1
3 NT382-0001		L1100	Nozzle – 1.7 mm w/holes	1
4 NT382-0002		AL262	Retainer nut	1

Consumables

Centricut part number	Reference number	Alternate reference	Description	Pkg qty
NT426-0515 (not shown)	4R018705-001		Nozzle – 1.5 mm ceramic standard	1
NT426-0520 (not shown)	4R018705-002		Nozzle – 2.0 mm ceramic standard	1
NT426-3962 (not shown)	4R003962-001		Cap – nozzle (standard)	1
NT426-6515 (not shown)	4R008865-002		Nozzle – 1.5 mm ceramic (small)	1
NT426-6520 (not shown)	4R008865-001		Nozzle – 2.0 mm ceramic (small)	1
NT426-8866 (not shown)	4R008866-001		Cap – nozzle (small)	1
NT426-8415 (not shown)	4R018452-001		Flange – 0.15" (new style)	1
NT426-8430 (not shown)	4R18452-002		Flange – 0.30" (new style)	1
NT426-4446 (not shown)	4R004446-001		Flange – 0.15" (old style)	1
NT426-6511 (not shown)	4R006511-001		Flange – 0.30" (old style)	1
NT426-8450 (not shown)	4R032035-001		Flange – 0.50" (new style)	1
NT426-2632 (not shown)	3R002632-G03		Nozzle holder – ceramic (old style)	1
NT426-6928 (not shown)	3R016928-G01		Nozzle holder – ceramic (new style)	1
NT426-3765 (not shown)	4R003765-001		Nozzle nut	1
NT426-3540 (not shown)	4R003540-001		Stylus	1
NT426-2720 (not shown)	4R012720-001		Stylus adaptor	1
NT426-1682 (not shown)	4R029911-001		Sensor cable – 216 mm (8.5")	1
NT426-8677 (not shown)	4R028677-001		Sensor Cable – Armored 508 mm (20")	1
NT426-4991 (not shown)	3-0104991		Sensor Cable – 482 mm (19") 90BNC/MCX	1
NT426-7492 (not shown)	3-0117492		Sensor Cable – 482 mm (19") 90BNC	1

New items shown in bold

Optics

Centricut part number	Reference number	Type	Diameter	Focal length	Edge thickness
Lenses					
NT375-6491	706491	PLX	1.5"	5.0"	.160"
NT375-8662	578662	PLX	1.5"	5.0"	.300"
NT375-4494	634494	PLX	2.0"	7.5"	.300"

Centricut part number	Reference number	Material	Diameter	Edge thickness
Phase shift mirrors				
NT375-8091	61785	SI	3.0"	.250"

Centricut part number	Reference number	Type	Material	Diameter	Edge thickness	S1
Zero phase shift mirrors and total reflectors						
NT375-8321	478321	TRZ	SI	1.75"	.160"	22.5
NT375-4442	304442	TRZ	SI	1.75"	.160"	45
NT375-1165		TRZ	CU	1.96"	0.59"	3.8CX-EG
NT375-9070		TRZ	CU	1.96"	0.59"	3.7CC-EG
NT375-7753	957753	TRZ	CU	1.96"	.984"	EG WC

Centricut part number	Reference number	Material	Diameter	Edge thickness	S1/Reflectivity	S2
Output couplers						
NT375-3547	793547	ZNSE	1.0"	.236"	20MCC	12MCX-65%
Rear mirrors						
NT375-0566	160566	GA	1.1"	.120"	20MCC-99.5%	

Optics care

Centricut part number	Reference number	Description	Pkg qty
TR300-6452	N/A	CO ₂ Lens paper (50 sheets)	1
TR300-SC20		Cotton swab – 20 piece	1
TR300-1115		Lens cleaning pre-cut cotton –100 piece	1
TR300-1010	AL1010	Dropper, lens cleaning fluid	1
TR300-255	AL255	Loupe, magnifying	1
TR300-271	AL271	Base, lens maintenance	1
TR300-7388	787388	Mirror polish (250 ml)	1

New items shown in bold

Ophir & Centricut by Talas = 100% Kwaliteitsgarantie & 100% OEM compatibiliteitsgarantie.

Talas is exclusief verdeler van o.a. lenzen & spiegels van **Ophir** voor BeLux en nozzles & ceramieken van **Centricut/Hypertherm** waardoor wij zeer competitieve tarieven hebben. Deze fabrikanten zijn tevens ook leverancier van de grootste fabrikanten(OEM) van lasersnijmachines.

Ophir, een CO² Optica groep en tweede grootste leverancier in de wereld is producent van het volledige gamma optieken voor de OEM en de vervangingsmarkt.

Ophir fabriceert lenzen met verschillende coatings voor een lagere absorptie en voor een langere levensduur:

-**Duralens**: max. absorptie $\leq 0,2\%$; standaard gele lens.

-**Black Magic**: max. absorptie $< 0,15\%$; niet transparante, niet-radioactieve harde coating voor een stabielere focuspunt en hogere warmte geleiding, vochtbestendige coating.

-**Clear Magic**: max. absorptie $< 0,13\%$; transparante, harde coating voor de beste focus stabiliteit en hoogste warmtebestendigheid, PMS-compatibel, vochtbestendige coating.

Centricut/Hypertherm nozzles in een kopertellurium legering, vervaardigd op CNC met diamanten werktuigen, gegarandeerd braamloze bewerking, optimale warmteweerstand, constante geleiding, verspanende tolerantie en concentriciteit $< 0,01\text{mm}$, zeer fijn afgewerkt binnenoppervlak voor een goede doorstroming van het gas en buitenafwerking tegen de hechting van de gesmolten materie, verchromde nozzles vermijden hechting van de gesmolten materie, dubbele nozzles voor een betere kwaliteit en hogere snijnelheid voor staal vanaf 8mm, lasermarkering van de diameter.

Ophir & Centricut by Talas = garantie à 100% de qualité et 100% de garantie compatibilité OEM

Talas est le distributeur exclusif de e.a. les lentilles et les miroirs de **Ophir** pour le BeLux et des buses & des céramiques de **Centricut/Hypertherm**. De ce fait nous avons des tarifs très compétitifs. Ces fabricants sont aussi fournisseurs des plus grands fabricants (OEM) des machines de découpe au laser.

Ophir, un groupe d'optique CO² et deuxième fournisseur en importance dans le monde, produit la gamme complète d'optiques pour l'OEM et le marché de pièces de rechange. Ophir fabrique des lentilles avec des revêtements différents pour un taux d'absorption inférieur et une durée de vie plus longue:

-**Duralens**: absorption maximale $\leq 0,2\%$, lentille standard jaune

-**Black Magic**: absorption maximale $< 0,15\%$, non transparent, revêtement dur non radioactifs pour un point focal plus stable et une conductivité thermique plus élevée, revêtement résistant à l'humidité

-**Clear Magic**: absorption maximale $< 0,13\%$, revêtement dur transparent pour la meilleure stabilité du point focal et la meilleure résistance à la chaleur, le revêtement PMS-conforme et résistant à l'humidité

Centricut/Hypertherm: buses dans un alliage cuivre-tellurium usinés avec outils diamant sur tours à CN, usinage garanti sans bavures, excellente résistance thermique, conductivité constante, tolérances d'usinage et de concentricité $< 0,01\text{ mm}$, la surface intérieure finement travaillée pour une bonne fluidité du gaz et une finition extérieure lisse contre l'accrochage de la matière en fusion, buses chromées évitant l'accrochage de la matière en fusion, double buses pour une meilleure qualité et plus grande vitesse de coupe de l'acier de 8 mm, marquage au laser du diamètre.

Type of nozzle & Reasons for selecting

Adapter This means that it is possible to use a different type of nozzle as long as the nozzle adaptor is purchased. It adapts from a big nozzle to a smaller nozzle and this can save the end-user money in the long run.

CP (chrome plated) CP nozzles are plated with chrome for increased durability. Chrome plated nozzles are much easier to clean and can withstand contact with material better than non-plated nozzles.

Conical This refers to the internal geometry of the nozzle. Due to the internal geometry the gas swirls and spirals down towards the material causing a coaxial flow, this flow prevents plugging of the orifice.

Cylindrical This refers to the internal geometry of the nozzle. Mainly used for gauge steel to 6,4 mm low pressure oxygen cutting.

Double Just as it sounds, this is a nozzle within a nozzle. Sometimes referred to as a "jacketed nozzle". Double nozzles are better for cutting thicker materials. "Better" refers to cut quality more than speed. Double nozzles have a high aspect ratio at the exit helping protect lens from back spatter.

Double with holes or double nozzle insert Used with the outer nozzle; the double nozzle insert inserts into the outer nozzle to form a double.

Double hard This is a double nozzle with the hard chrome plating (this type of chrome plating is only available in North America).

Hard Hard chrome plating (only available in North America), is harder than standard chrome therefore it is more durable.

Hex Hex refers to the machined edge of the nozzle, with the hex machined in it makes it possible to get an open end wrench on the nozzle for tightening and loosening.

High pressure (HP) High density (HD) Used in applications where the gas pressures are really high, used on thicker material and stainless steel and aluminium.

Low pressure Used for low pressure oxygen cutting applications such as gauge material up to 3,2 mm.

Nozzle holder The nozzle holder sometimes also known as the ceramic is the mating partner for the nozzle; the two are combined by threading the nozzle into the holder.

Nozzle, long Refers to the length of the nozzle.

Nozzle, short Refers to the length of the nozzle.

Nozzle, w/step This refers to the internal geometry of the nozzle. Mainly used in higher pressure cutting.

Outer nozzle See double nozzle. This is the mating partner of the double nozzle insert, the two combined make a double nozzle.

Shower Used to cut thick mild steel ($> 6,4\text{ mm}$) w/O₂ assist gas. Shower nozzles have a center nozzle orifice, surrounded by several other holes. This design ensures more effective assist gas volume, without significantly increasing real volume.

Straight taper This refers to the internal geometry of the nozzle, mainly used in higher pressure cutting.

WACS Water-assist cutting system.



TALAS

Paardenkerkhofstraat 56 B-2800 Mechelen
Tel. +32(0)15.61.60.07 Fax. +32(0)15.61.75.27
Email. info@talas.be